

ETSI EN 302 195 V2.1.1 (2016-06)



**Short Range Devices (SRD);
Ultra Low Power Active Medical Implants (ULP-AMI)
and accessories (ULP-AMI-P) operating in the
frequency range 9 kHz to 315 kHz
Harmonised Standard covering the essential requirements
of article 3.2 of the Directive 2014/53/EU**

Reference

REN/ERM-TG30-310

Keywords

health, inductive, magnetic, mobile, radio,
regulation, short range, SRD, testing

ETSI

650 Route des Lucioles
F-06921 Sophia Antipolis Cedex - FRANCE

Tel.: +33 4 92 94 42 00 Fax: +33 4 93 65 47 16

Siret N° 348 623 562 00017 - NAF 742 C
Association à but non lucratif enregistrée à la
Sous-Préfecture de Grasse (06) N° 7803/88

Important notice

The present document can be downloaded from:
<http://www.etsi.org/standards-search>

The present document may be made available in electronic versions and/or in print. The content of any electronic and/or print versions of the present document shall not be modified without the prior written authorization of ETSI. In case of any existing or perceived difference in contents between such versions and/or in print, the only prevailing document is the print of the Portable Document Format (PDF) version kept on a specific network drive within ETSI Secretariat.

Users of the present document should be aware that the document may be subject to revision or change of status. Information on the current status of this and other ETSI documents is available at
<https://portal.etsi.org/TB/ETSIDeliverableStatus.aspx>

If you find errors in the present document, please send your comment to one of the following services:
<https://portal.etsi.org/People/CommitteeSupportStaff.aspx>

Copyright Notification

No part may be reproduced or utilized in any form or by any means, electronic or mechanical, including photocopying and microfilm except as authorized by written permission of ETSI.

The content of the PDF version shall not be modified without the written authorization of ETSI.
The copyright and the foregoing restriction extend to reproduction in all media.

© European Telecommunications Standards Institute 2016.
All rights reserved.

DECT™, **PLUGTESTS™**, **UMTS™** and the ETSI logo are Trade Marks of ETSI registered for the benefit of its Members.
3GPP™ and **LTE™** are Trade Marks of ETSI registered for the benefit of its Members and of the 3GPP Organizational Partners.
GSM® and the GSM logo are Trade Marks registered and owned by the GSM Association.

Contents

Intellectual Property Rights	6
Foreword.....	6
Modal verbs terminology.....	6
Introduction	6
1 Scope	8
2 References	8
2.1 Normative references	8
2.2 Informative references.....	9
3 Definitions, symbols and abbreviations	9
3.1 Definitions	9
3.2 Symbols.....	10
3.3 Abbreviations	10
4 Technical requirements specifications	11
4.1 Environmental profile.....	11
4.2 Transmitter requirements	11
4.2.1 Radiated field strength	11
4.2.1.0 General	11
4.2.1.1 Radiated H-field	11
4.2.1.1.0 General	11
4.2.1.1.1 Definition.....	11
4.2.1.1.2 Limits	12
4.2.1.1.3 Conformance	12
4.2.2 Permitted range of modulation bandwidth.....	12
4.2.2.0 General	12
4.2.2.1 Definition	12
4.2.2.2 Limits	12
4.2.2.3 Conformance	13
4.2.3 Spurious emissions	13
4.2.3.0 General	13
4.2.3.1 Definition	13
4.2.3.2 Limits	13
4.2.3.3 Conformance.....	13
4.2.4 Duty cycle.....	13
4.2.4.0 General	13
4.2.4.1 Definitions.....	13
4.2.4.2 Limits	13
4.2.4.3 Conformance	13
4.3 Receiver requirements	14
4.3.1 Receiver Classification	14
4.3.2 Blocking.....	14
4.3.2.0 General	14
4.3.2.1 Definition	14
4.3.2.2 Limits	14
4.3.2.3 Conformance.....	15
4.3.3 Receiver spurious radiations	15
4.3.3.0 General	15
4.3.3.1 Definition	15
4.3.3.2 Limits	15
4.3.3.3 Conformance.....	15
5 Testing for compliance with technical requirements.....	15
5.1 Environmental conditions for testing	15
5.1.0 General remarks	15
5.1.1 Presentation of equipment for testing purposes	16

5.1.2	Choice of model for testing	16
5.1.3	Presentation of equipment that does not have an external 50 Ω RF connector (integral antenna equipment)	16
5.1.3.0	General remarks	16
5.1.3.1	Equipment with an internal permanent or temporary antenna connector	16
5.1.3.2	Equipment with a temporary antenna connector	16
5.1.4	Controls	17
5.1.5	Transmitter shut-off facility	17
5.1.6	Receiver power save capability	17
5.1.7	Equipment intended to be implanted in a human body	17
5.1.8	Declarations by the Applicant	17
5.1.9	Auxiliary test equipment	17
5.1.10	Test conditions	17
5.1.10.1	Normal and extreme test-conditions	17
5.1.10.2	Test power source	17
5.1.10.2.0	General remarks	17
5.1.10.2.1	External test power source	18
5.1.10.2.2	Internal test power source	18
5.1.10.3	Normal test Condition	18
5.1.10.3.1	Normal temperature and humidity	18
5.1.10.3.2	Normal test power source	18
5.1.10.4	Extreme test conditions	19
5.1.10.4.1	Extreme temperatures	19
5.1.10.4.2	Extreme test source voltages	20
5.1.10.5	Normal test signals and test modulation	21
5.1.10.5.0	General remarks	21
5.1.10.5.1	Normal modulation test signals for data	21
5.1.10.6	Antenna	21
5.1.10.6.0	General remarks	21
5.1.10.6.1	Artificial Antenna	21
5.1.10.7	Test fixture	22
5.1.10.7.0	General remarks	22
5.1.10.7.1	Alternate test fixture for equipment intended to be implanted within a human body	22
5.1.10.8	Test sites and general arrangements for radiated measurements	22
5.1.10.9	Modes of operation of the transmitter	22
5.1.10.10	Measuring receiver	23
5.2	Interpretation of the measurement results	23
5.3	Method of Measurements	23
5.3.1	Radiated field strength	23
5.3.1.0	General remarks	23
5.3.1.1	Radiated Field Strength (H-field)	24
5.3.2	Permitted frequency range of the modulation bandwidth	24
5.3.3	Spurious emissions	25
5.3.4	Receiver requirement	25
5.3.4.1	Blocking	25
5.3.4.2	Receiver spurious radiation	26
Annex A (normative):	Relationship between the present document and the essential requirements of Directive 2014/53/EU	27
Annex B (normative):	Radiated measurements	28
B.1	Test sites and general arrangements for measurements involving the use of radiated fields	28
B.1.1	Outdoor test site	28
B.1.1.0	General remarks	28
B.1.1.1	Standard position	28
B.1.1.2	Equipment in close proximity to the human body but external to it	29
B.1.1.3	Active medical implant equipment	29
B.1.2	Test antenna	31
B.1.2.1	Below 30 MHz	31
B.1.3	Optional additional indoor site	31
B.2	Guidance on the use of radiation test sites	31

B.2.0	General remarks	31
B.2.1	Measuring distance	32
B.2.2	Auxiliary cables.....	32
Annex C (normative):	H-field measurements at other distances than 10 m.....	33
Annex D (informative):	Bibliography.....	35
History		36

Intellectual Property Rights

IPRs essential or potentially essential to the present document may have been declared to ETSI. The information pertaining to these essential IPRs, if any, is publicly available for **ETSI members and non-members**, and can be found in ETSI SR 000 314: "*Intellectual Property Rights (IPRs); Essential, or potentially Essential, IPRs notified to ETSI in respect of ETSI standards*", which is available from the ETSI Secretariat. Latest updates are available on the ETSI Web server (<https://ipr.etsi.org/>).

Pursuant to the ETSI IPR Policy, no investigation, including IPR searches, has been carried out by ETSI. No guarantee can be given as to the existence of other IPRs not referenced in ETSI SR 000 314 (or the updates on the ETSI Web server) which are, or may be, or may become, essential to the present document.

Foreword

This Harmonised European Standard (EN) has been produced by ETSI Technical Committee Electromagnetic compatibility and Radio spectrum Matters (ERM).

The present document has been prepared under the Commission's standardisation request C(2015) 5376 final [i.6] to provide one voluntary means of conforming to the essential requirements of Directive 2014/53/EU on the harmonisation of the laws of the Member States relating to the making available on the market of radio equipment and repealing Directive 1999/5/EC [i.2].

Once the present document is cited in the Official Journal of the European Union under that Directive, compliance with the normative clauses of the present document given in table A.1 confers, within the limits of the scope of the present document, a presumption of conformity with the corresponding essential requirements of that Directive and associated EFTA regulations.

National transposition dates	
Date of adoption of this EN:	14 June 2016
Date of latest announcement of this EN (doa):	30 September 2016
Date of latest publication of new National Standard or endorsement of this EN (dop/e):	31 March 2017
Date of withdrawal of any conflicting National Standard (dow):	31 March 2018

Modal verbs terminology

In the present document "**shall**", "**shall not**", "**should**", "**should not**", "**may**", "**need not**", "**will**", "**will not**", "**can**" and "**cannot**" are to be interpreted as described in clause 3.2 of the [ETSI Drafting Rules](#) (Verbal forms for the expression of provisions).

"**must**" and "**must not**" are **NOT** allowed in ETSI deliverables except when used in direct citation.

Introduction

The present document covers Ultra Low Power Active Medical Implant (ULP-AMI) and any associated non-implantable Peripherals (ULP-AMI-P) equipment incorporating low frequency technology, which is designed to operate in the frequency range of 9 kHz to 315 kHz for the purpose of providing a digital communication link.

The present document includes methods of measurement for ULP-AMI and ULP-AMI-P incorporating attachable/detachable antenna connector(s) and/or integral antenna(s). Equipment designed for use with an integral antenna may use a temporary or permanent internal connector for the purpose of testing, provided the characteristics being measured are representative of the final product placed on the market.

If equipment already placed on the market is required to be inspected it should be tested in accordance with the methods of measurement specified in the present document.

Clauses 1 through 3 provide a general description on the types of equipment covered by the present document and the definitions, symbols and abbreviations used.

Clause 4 provides the technical requirements specifications, limits and conformance relative to transmitter and receiver function.

Clauses 5.1 and 5.2 specify the conditions for testing of the equipment and interpretation of the measurement results with the maximum measurement uncertainty values.

Clause 5.3 specifies the required measurement methods.

Annex A (normative) provides the relationship between the present document and the essential requirements of Directive 2014/53/EU [i.2].

Annex B (normative) provides specifications concerning radiated measurements.

Annex C (normative) provides procedures for H-field measurements at other distances than 10 m.

Annex D (informative) bibliography; provides additional information.

1 Scope

The present document applies to ULP-AMI equipment operating in the frequency range from 9 kHz to 315 kHz and any associated Peripherals (ULP-AMI-P) transmitters and receivers operating in the frequency range of 9 kHz to 315 kHz including external programmers and patient related telecommunication devices using digital modulation techniques such as, but not limited to, FSK or pulse position modulation. Analogue voice modulation is not within the scope of the present document.

The present document applies to ULP-AMI/ULP/AMI-P transmitters and receivers:

- transmitters operating in range from 9 kHz to 315 kHz with power levels ranging up to 30 dBuA/m at 10m;
- receivers operating in the range from 9 kHz to 315 kHz.

The present document applies to ULP-AMI devices:

- either with a Radio Frequency (RF) output connection and dedicated antenna, or with an integral antenna;
- for telecommand, telemetry etc. applications;
- for all types of digital modulation.

The present document covers ULP-AMI-P fixed stations (physician programmer/controllers), mobile stations (patient programmers, handheld or otherwise) and portable stations (implanted devices providing medical benefit to the implanted patient).

The present document contains the technical requirements for characteristics of ULP-AMI/ULP-AMI-P radio equipment which are aligned with annex 12 Sub-band (a) of CEPT/ERC Recommendation 70-03 [i.1].

The present document contains requirements to demonstrate that Ultra Low Power Active Medical Implants (ULP-AMI) and Peripherals (ULP-AMI-P) operating in the frequency range 9 kHz to 315 kHz *"shall be so constructed that it both effectively uses and supports the efficient use of radio spectrum in order to avoid harmful interference"* (article 3.2 of the Directive 2014/53/EU) [i.2]. It does not necessarily include all the characteristics, which may be required by a user, nor does it necessarily represent the optimum performance achievable.

2 References

2.1 Normative references

References are either specific (identified by date of publication and/or edition number or version number) or non-specific. For specific references, only the cited version applies. For non-specific references, the latest version of the referenced document (including any amendments) applies.

Referenced documents which are not found to be publicly available in the expected location might be found at <http://docbox.etsi.org/Reference>.

NOTE: While any hyperlinks included in this clause were valid at the time of publication, ETSI cannot guarantee their long term validity.

The following referenced documents are necessary for the application of the present document.

Not applicable.

2.2 Informative references

References are either specific (identified by date of publication and/or edition number or version number) or non-specific. For specific references, only the cited version applies. For non-specific references, the latest version of the referenced document (including any amendments) applies.

NOTE: While any hyperlinks included in this clause were valid at the time of publication, ETSI cannot guarantee their long term validity.

The following referenced documents are not necessary for the application of the present document but they assist the user with regard to a particular subject area.

- [i.1] CEPT/ERC Recommendation 70-03: "Relating to the use of Short Range Devices (SRD)".
- [i.2] Directive 2014/53/EU of the European Parliament and of the Council of 16 April 2014 on the harmonisation of the laws of the Member States relating to the making available on the market of radio equipment and repealing Directive 1999/5/EC.
- [i.3] ETSI TR 100 028 (all parts) (V1.4.1): "Electromagnetic compatibility and Radio spectrum Matters (ERM); Uncertainties in the measurement of mobile radio equipment characteristics".
- [i.4] Recommendation ITU-T O.153: "Basic parameters for the measurement of error performance at bit rates below the primary rate".
- [i.5] Air Force Technical Report AL/OE-TR-1996-0037: "Compilation of the Dielectric Properties of Body Tissues at RF and Microwave Frequencies", Camelia Gabriel.
- [i.6] Commission Implementing Decision C(2015) 5376 final of 4.8.2015 on a standardization request to the European Committee for Electrotechnical Standardization and to the European Telecommunications Standards Institute as regards radio equipment in support of Directive 2014/53/EU of the European Parliament and of the Council.

3 Definitions, symbols and abbreviations

3.1 Definitions

For the purposes of the present document, the following terms and definitions apply:

active medical implant: diagnostic or therapeutic device designed to be implanted in a human body containing a power source and capable of generating radio frequency energy within the 9 kHz to 315 kHz frequency band for the purpose of providing a digital communications link

artificial antenna: tuned reduced-radiating dummy load equal to the nominal impedance specified by the applicant

assigned frequency: frequency within the applicable band on which the device is authorized to operate

conducted measurements: measurements which are made using a direct connection to the equipment under test

custom antenna: antenna built according to providers antenna design rules

dedicated antenna: removable antenna supplied and tested with the radio equipment that is designed as an indispensable part of the equipment

fixed station: equipment intended for use in a fixed location

H-field test antenna: electrically screened loop or equivalent antenna, with which the magnetic component of the field can be measured

integral antenna: permanent fixed antenna, which may be built-in, that is designed as an indispensable part of the equipment

magnetic dipole moment: product of (Number of coil turns) \times (coil area) \times (coil current)

NOTE: Air coils only.

medical implant device: apparatus that includes a transmitter with an integral receiver that operates in the ULP-AMI band that is placed inside the human body for the purpose of performing diagnostic functions and/or delivery of therapeutic treatment

medical implant programmer/control transmitter: transmitter, operating outside of a human body in the ULP-AMI frequency band that transfers information to/from the implant after a communications link is initiated

mobile station: equipment external to the body, normally used by a patient, to provide telecommand or telemetry communication functions to a medical implant device placed within the body

patient activator: equipment intended to be used by a patient to communicate with an implanted device

portable station: equipment intended to be carried, attached or implanted in a human body that is operated at a separation distance less than 20 cm from or internal to a human body

programmer/controller: ULP-AMI equipment used by a physician to communicate with an implanted device

radiated measurements: measurements which involve the absolute measurement of a radiated field

telecommand: use of radio communication for the transmission of signals to initiate, modify or terminate functions of equipment at a distance

telecommunications: use of radio communications for the transmission of data between various ULP-AMI devices

telemetry: use of radio communication for indicating or recording data at a distance

Ultra Low Power Active Medical Implant (ULP-AMI): active medical implant transmitter that is designed to radiate RF energy in accordance with the provisions of annex 12, sub-band (a) and to CEPT/ERC Recommendation 70-03 [i.1]

Ultra Low Power Active Medical Implant Peripheral (ULP-AMI-P): associated medical implant programmer/control radio part located outside the human body that communicates with an ULP-AMI in accordance with the provisions of annex 12, sub-band (a) of CEPT/ERC Recommendation 70-03 [i.1]

3.2 Symbols

For the purposes of the present document, the following symbols apply:

f	frequency
H	Magnetic field strength
H ₀	Reference magnetic field strength
m	magnetic dipole moment
P	Power
R	Distance
R ₀	Reference distance
t	time

3.3 Abbreviations

For the purposes of the present document, the following abbreviations apply:

CEPT	European Conference of Postal & Telecommunications Administrations
EMC	ElectroMagnetic Compatibility
ERC	European Research Council
EUT	Equipment Under Test
FSK	Frequency Shift Keying
RF	Radio Frequency
SRD	Short Range Device
ULP-AMI	Ultra Low Power Active Medical Implant
ULP-AMI-P	Ultra Low Power Active Medical Implant Peripheral

4 Technical requirements specifications

4.1 Environmental profile

The technical requirements of the present document apply under the environmental profile for operation of the equipment, which shall be declared by the supplier. The equipment shall comply with all the technical requirements of the present document at all times when operating within the boundary limits of the declared operational environmental profile.

4.2 Transmitter requirements

4.2.1 Radiated field strength

4.2.1.0 General

Transmitters covered by the present document are considered to have internal and/or dedicated external antennas. In this case, radiated field strength measurements are required. User defined antenna systems are not permitted.

4.2.1.1 Radiated H-field

4.2.1.1.0 General

The radiated H-field, as defined in clause 4.2.1.1.1, shall not exceed the limits of clause 4.2.1.1.2.

4.2.1.1.1 Definition

4.2.1.1.1.0 General

In the case of a transmitter with an integral or dedicated antenna, the H-field is measured in the direction of maximum field strength under specified conditions of measurement.

4.2.1.1.1.1 The inductive loop coil transmitters

These transmitters are characterized by:

- a) the loop coil antenna area A shall be $< 30 \text{ m}^2$;
- b) the length of any antenna loop element shall be $< \frac{\lambda}{4}$ ($< \frac{75}{f}$, where f is in MHz) or $< 30 \text{ m}$ whichever is shorter;
- c) antenna coil may have one or multiple turns.

4.2.1.1.1.2 Antenna types

This equipment is defined according to the antenna types referenced in CEPT/ERC Recommendation 70-03 [i.1].

Inductive loop coil transmitter, tested with an antenna as either:

- an integral antenna (antenna type 1); or
- a dedicated antenna supplied with the equipment (antenna type 2).

The following restrictions apply to these antenna types:

- 9 kHz to 315 kHz frequency range;

- no field customization of the antenna(s);
- loop antenna area $< 30 \text{ m}^2$; and
- the length of any antenna loop element shall be $< \frac{\lambda}{4}$ ($< \frac{75}{f}$, where f is in MHz) or $< 30 \text{ m}$ whichever is shorter.

The transmitter carrier and spurious are limited by the maximum generated H-field, (see clauses 4.2.1.1.2 and 4.2.3.2 respectively).

Where a manufacturer provides a range of standard antennas, the equipment will be tested with each antenna attached.

4.2.1.1.2 Limits

Maximum field strength under normal and extreme conditions is given in table 1.

The limits for the maximum radiated field strength within the band 9 kHz to 315 kHz are provided in table 1.

Table 1: H-field limits at 10 m

Frequency range (MHz)	H-field strength limit (H_f) dB μ A/m at 10 m
$0,009 \leq f \leq 0,315$	30
NOTE: Systems operating below 135 kHz may alternately choose to show conformance according to the limits and technical standards specified in annex 9 of CEPT/ERC Recommendation 70-03 [i.1].	

Additional information is available in CEPT/ERC Recommendation 70-03 [i.1].

4.2.1.1.3 Conformance

Conformance test as defined in clause 5.3.1.1 of the present document shall be carried out.

4.2.2 Permitted range of modulation bandwidth

4.2.2.0 General

The permitted range of operation frequencies, as defined in clause 4.2.2.1, shall not exceed the limits in clause 4.2.2.2.

4.2.2.1 Definition

The modulation bandwidth contains all associated side bands above the following level:

- a) for carrier frequencies in the range of 9 kHz to 315 kHz, at the highest level of either:
 - 20 dB below the carrier, or
 - the appropriate spurious limit, see clause 4.2.3.2.

Where the assigned frequency band has been divided into sub-bands by the regulatory body, the above measuring levels and bandwidths apply inside these sub-bands.

Devices whose carrier level is below the spurious limit (clause 4.2.3.2), do not have a defined modulation bandwidth.

4.2.2.2 Limits

The permitted range of the modulation bandwidth shall be within the limits of the 9 kHz to 315 kHz designated frequency band stated in annex 12 sub-band (a) of CEPT/ERC Recommendation 70-03 [i.1].

4.2.2.3 Conformance

Conformance test as defined in clause 5.3.2 of the present document shall be carried out.

4.2.3 Spurious emissions

4.2.3.0 General

The spurious emissions, as defined in clause 4.2.3.1, shall not exceed the limits in clause 4.2.3.2.

This requirement applies to all transmitters.

4.2.3.1 Definition

Spurious emissions are emissions at frequencies other than those of the carrier and sidebands associated with normal test modulation (clause 5.1.10.5). The level of spurious emissions shall be measured only for frequencies below 30 MHz at normal conditions (clause 5.1.10.3) as:

- 1) their effective radiated power or field strength when radiated by the cabinet with integral antenna, if applicable, and any other dedicated antenna supplied by the manufacturer.

4.2.3.2 Limits

Radiated spurious emissions below 30 MHz shall not exceed the generated H-field dB μ A/m at 10 m given in table 2.

Table 2

State	Frequency $9 \text{ kHz} \leq f < 10 \text{ MHz}$	Frequency $10 \text{ MHz} \leq f < 30 \text{ MHz}$
Transmit	10 dB μ A/m	-10 dB μ A/m
Standby	-5 dB μ A/m	-25 dB μ A/m

4.2.3.3 Conformance

Conformance test as defined in clause 5.3.3 of the present document shall be carried out.

4.2.4 Duty cycle

4.2.4.0 General

The duty cycle, as defined in clause 4.2.4.1, shall be bound by the duty cycle limit in clause 4.2.4.2.

4.2.4.1 Definitions

For the purpose of the present document the term duty cycle refers to the ratio of the total on time of the "message" to the total off time in any one hour period under repeated operation during the time measurement interval. The device may be triggered either automatically or manually and depending on how the device is triggered will also depend on whether the duty cycle is fixed or random.

4.2.4.2 Limits

In a period of 1 hour the duty cycle shall not exceed 10 %.

4.2.4.3 Conformance

For software controlled or pre-programmed devices, the applicant shall declare in the test report the duty cycle for the equipment under test, not to exceed 10 %.

For manually activated or event dependant devices, with or without software controlled functions, the applicant shall declare whether the device once triggered, follows a pre-programmed cycle, or whether the transmission is constant until the activation mechanism is released or otherwise reset. The applicant shall also give a description of the application for the device and include a typical usage pattern for maximizing duty cycle that would occur in a period of 1 hour. The typical usage pattern as declared by the applicant shall be used to determine the duty cycle, not to exceed 10 %.

Where an acknowledgement is required, the additional transmitter on-time shall be included and declared by the manufacturer in the test report.

4.3 Receiver requirements

4.3.1 Receiver Classification

The product family of ULP-AMI and ULP-AMI-P radio devices is divided into three Equipment Classes, see table 3, each having its own set of minimum performance criteria. This classification is based upon the impact on persons in case the equipment does not operate above the specified minimum performance level. Applicable equipment classification shall be specified by the manufacturer in the test report.

Table 3

Receiver class	Relevant receiver clauses	Risk assessment of receiver performance
1	4.3.2 and 4.3.3	Highly reliable ULP-AMI and ULP-AMI-P communication media; e.g. serving human life inherent systems (may result in a physical risk to a person)
2	4.3.2 and 4.3.3	Medium reliable ULP-AMI and ULP-AMI-P communication media e.g. causing Inconvenience to persons, which cannot simply be overcome by other means
3	4.3.3	Standard reliable ULP-AMI and ULP-AMI-P communication media e.g. Inconvenience to persons, which can simply be overcome by other means (e.g. manual)
NOTE: In particular where an ULP-AMI or ULP-AMI-P which may have an inherent safety of human life implication, manufacturers and users should pay particular attention to the potential for interference from other systems operating in the same or adjacent bands.		

4.3.2 Blocking

4.3.2.0 General

The blocking, as defined in clause 4.3.2.1 shall not be less than the limits in clause 4.3.2.2.

4.3.2.1 Definition

Blocking is a measure of the capability of the receiver to receive a wanted modulated signal without exceeding a given degradation due to the presence of an unwanted input signal at any frequencies other than those of the spurious responses adjacent selectivity. Receivers implanted in a human body that use error detection coding and recognize a limited command set such as pacemakers, defibrillators, etc., are not required to perform this test.

4.3.2.2 Limits

The blocking ratio, for any frequency within the specified ranges, shall not be less than the values given in table 4, except at frequencies on which spurious responses are found. The limit value is determined by a reference limit (Ref) plus a correction factor (dB) depending of the appropriate receiver classification.

Table 4: Receiver blocking limits

Receiver Classification	Generator B frequency offset from band edge	Limit
1	2 x receiver bandwidth or 50 kHz whichever is greater	Ref
2	2 x receiver bandwidth or 50 kHz whichever is greater	Ref -15 dB
	4 x receiver bandwidth or 50 kHz whichever is greater	Ref -10 dB
	8 x receiver bandwidth or 50 kHz whichever is greater	Ref -5 dB
	20 x receiver bandwidth or 50 kHz whichever is greater	Ref
Reference limit (Ref) = 30 dB at 9 kHz increasing with 10 dB/decade to 65 dB at 30 MHz.		

The receiver performance shall be in conformity with the specifications declared by the manufacturer in the test report.

4.3.2.3 Conformance

Conformance test as defined in clause 5.3.4.1 of the present document shall be carried out.

4.3.3 Receiver spurious radiations

4.3.3.0 General

The spurious radiations below 30 MHz, as defined in clause 4.3.3.1, shall not exceed the limits in clause 4.3.3.2.

Measurements above 30 MHz are not required.

4.3.3.1 Definition

Spurious radiation from receivers consists of emissions radiated from the antenna, the chassis and case of the receiver. It is specified as the radiated power of a discrete signal. Included in this definition are modulation products that are outside the 20 dB down point on either side of the fundamental emission.

4.3.3.2 Limits

The spurious components below 30 MHz shall not exceed the generated H-field dB μ A/m values at 10 m according to table 5.

Table 5: Receiver spurious radiation limits

Frequency 9 kHz $\leq f < 10$ MHz	Frequency 10 MHz $\leq f < 30$ MHz
-5 dB μ A/m	-25 dB μ A/m

4.3.3.3 Conformance

Conformance test as defined in clause 5.3.4.2 of the present document shall be carried out.

5 Testing for compliance with technical requirements

5.1 Environmental conditions for testing

5.1.0 General remarks

Tests defined in the present document shall be carried out at representative points within the boundary limits of the declared operational environmental profile.

Where technical performance varies subject to environmental conditions, tests shall be carried out under a sufficient variety of environmental conditions (within the boundary limits of the declared operational environmental profile) to give confidence of compliance for the affected technical requirements.

5.1.1 Presentation of equipment for testing purposes

Each equipment submitted for testing shall fulfil the requirements of the present document on all frequencies over which it is intended to operate. Compliance with this requirement should be shown by testing each unit at the fundamental frequency as declared by the provider.

The provider shall complete the appropriate application form when submitting the equipment for testing. In addition, the provider shall declare the range of operating conditions and power requirements, as applicable; to establish the appropriate test conditions.

Additionally, technical documentation and operating manuals, sufficient to make the test, shall be supplied for all ULP-AMI-P and ULP-AMI.

Measurements shall be performed, according to the present document, on samples of equipment defined in clauses 5.1.2 and 5.1.3.

5.1.2 Choice of model for testing

The applicant shall provide one or more samples of the equipment, as appropriate for testing.

Stand-alone equipment shall be offered by the applicant complete with any ancillary equipment needed for testing.

If equipment has several optional features, considered not to affect the RF parameters then the tests need only to be performed on the equipment configured with that combination of features considered to be the most complex, as proposed by the applicant and agreed by the test laboratory.

In the case of integral or dedicated antenna equipment, if the equipment does not have an internal permanent 50 Ω connector then it is permissible to supply a second sample of the equipment with a temporary antenna connector fitted to facilitate testing, see clause 5.1.3.

5.1.3 Presentation of equipment that does not have an external 50 Ω RF connector (integral antenna equipment)

5.1.3.0 General remarks

This type of equipment will normally be tested by performing radiated tests at 10 m. For devices with very low radiated field levels, measurements may be made at closer distance and the levels extrapolated to 10 m using the procedures in annex C.

5.1.3.1 Equipment with an internal permanent or temporary antenna connector

The means to access and/or implement the internal permanent or temporary antenna connector shall be stated by the applicant with the aid of a diagram. The fact that use has been made of the internal antenna connection, or of a temporary connection, to facilitate measurements shall be recorded in the test report.

5.1.3.2 Equipment with a temporary antenna connector

The applicant may submit one set of equipment with the normal antenna connected, to enable radiated measurements to be made. The applicant shall attend the test laboratory at the conclusion of the radiated measurements, to disconnect the antenna and fit the temporary connector if needed. The testing laboratory staff shall not connect or disconnect any temporary antenna connector.

Alternatively, the applicant may submit two sets of equipment to the test laboratory, one fitted with a temporary antenna connector with the antenna disconnected and another equipment with the antenna connected. Each equipment shall be used for the appropriate tests. The applicant shall declare that the two sets of equipment are identical in all aspects except for the antenna connector.

5.1.4 Controls

Those controls which, if maladjusted, might increase the interfering potentialities of the equipment should not be easily accessible to the user.

5.1.5 Transmitter shut-off facility

If the transmitter is equipped with an automatic transmitter shut-off facility, it should be made inoperative for the duration of the test.

5.1.6 Receiver power save capability

If the receiver is equipped with a battery-saving circuit, this circuit should be made inoperative for the duration of the tests.

5.1.7 Equipment intended to be implanted in a human body

For measurement purposes, to determine compliance with all emission limits, active medical implants may be tested in a fixture that approximates the physical conditions of an implant transmitter placed in a human body. This fixture, a human torso simulator, with the implant mounted inside, shall be filled with a tissue substitute material and placed on the radiated emissions test site turntable with the implant at a height of 1,5 m above the ground plane for testing purposes. The tissue substitute material conductivity and dielectric parameters shall be in accordance with clause B.1.1.3. Typically they will be equivalent to those of human muscle tissue at the fundamental frequency or alternatively these parameters may be adjusted to correspond to the measurement frequency. The tissue substitute material shall be sufficiently fluid that it will flow around the implant without creating any voids.

5.1.8 Declarations by the Applicant

When submitting equipment for testing, the applicant shall supply the necessary information required by the test laboratory.

The performance of the equipment submitted for testing shall be a representative sample of the equipment.

5.1.9 Auxiliary test equipment

All necessary test signal sources, test fixtures, specialized test apparatus and set-up information shall accompany the equipment when it is submitted for type testing unless alternative arrangements are agreed to by the test laboratory and the manufacturer.

5.1.10 Test conditions

5.1.10.1 Normal and extreme test-conditions

The test conditions shall be as declared by the provider.

5.1.10.2 Test power source

5.1.10.2.0 General remarks

The equipment shall be tested using the appropriate test power source as specified in clauses 5.1.10.2.1 or 5.1.10.2.2. Where equipment can be powered using either external or internal power sources, then the equipment shall be tested using the external power source as specified in clause 5.1.10.2.1 then repeated using the internal power source as specified in clause 5.1.10.2.2.

The test power source used shall be stated in the test report.

5.1.10.2.1 External test power source

During type tests, the power source of the equipment shall be replaced by an external test power source capable of producing normal and extreme test voltages as specified in clauses 5.1.10.3.2 and 5.1.10.4.2 respectively. The internal impedance of the external test power source shall be low enough for its effect on the test results to be negligible. For the purpose of the tests, the voltage of the external test power source shall be measured at the input terminals of the equipment. The external test power source shall be suitably de-coupled as close to the equipment battery terminals as practicable. For radiated measurements any external power leads should be so arranged so as not to affect the measurements.

During tests the test power source voltages shall be within a tolerance of $< \pm 1$ % relative to the voltage at the beginning of each test. The value of this tolerance can be critical for certain measurements. Using a smaller tolerance will provide a better uncertainty value for these measurements.

5.1.10.2.2 Internal test power source

For radiated measurements on portable equipment with integral antenna, fully charged internal batteries should be used. The batteries used should be as supplied or recommended by the applicant. If internal batteries are used, at the end of each test the voltage shall be within a tolerance of $< \pm 5$ % relative to the voltage at the beginning of each test. For portable devices where the batteries cannot be measured or replaced but have telemetry readout of battery voltage, it is acceptable to record the starting and ending voltages as provided by the telemetry readout. This shall be stated in the test report.

If appropriate, for conducted measurements or where a test fixture is used, an external power supply at the required voltage may replace the supplied or recommended internal batteries. This shall be stated on the test report.

For equipment intended to be implanted in a human body that is hermetically sealed it may not be possible to measure the battery voltage directly or indirectly. For this type of equipment, it is not necessary to measure the voltage at the end of each test; however, care shall be taken to ensure that the internal battery supply voltage does not fall below the manufacturer's specification for normal operating voltage range. For battery operated devices, it is acceptable to read the battery voltage via telemetry readout.

5.1.10.3 Normal test Condition

5.1.10.3.1 Normal temperature and humidity

The normal temperature and humidity conditions for tests for devices external to the human body shall be any convenient combination of temperature and humidity within the following ranges:

- temperature +15 °C to +37 °C;
- relative humidity 20 % to 75 %.

Active medical implant transmitters operate after implant in a human body. Accordingly, the body tends to serve as an oven to maintain the implant temperature near 37 °C. Therefore, the normal temperature and humidity conditions for implant transmitters shall be within the following ranges:

- temperature +36 °C to +38 °C;
- relative humidity not applicable.

When it is impracticable to carry out tests under these conditions, a note to this effect, stating the ambient temperature and relative humidity during the tests, shall be added to the test report.

5.1.10.3.2 Normal test power source

5.1.10.3.2.1 Mains voltage

The normal test voltage for equipment to be connected to the mains shall be the nominal mains voltage. For the purpose of the present document, the nominal voltage shall be the declared voltage, or any of the declared voltages, for which the equipment was designed.

The frequency of the test power source corresponding to the ac mains shall be between 49 Hz and 51 Hz.

5.1.10.3.2.2 Regulated lead-acid battery power sources

When the radio equipment is intended for operation with the usual types of regulated lead-acid battery power source, the normal test voltage shall be 1,1 multiplied by the nominal voltage of the battery (e.g. 6 V, 12 V, etc.).

5.1.10.3.2.3 Other power sources

For operation from other power sources or types of battery (primary or secondary), the normal test voltage shall be that declared by the equipment applicant and agreed by the accredited test laboratory. Such values shall be stated in the test report.

5.1.10.4 Extreme test conditions

5.1.10.4.1 Extreme temperatures

5.1.10.4.1.1 Procedure for tests at extreme temperatures

5.1.10.4.1.1.0 General remarks

Before measurements are made the equipment shall have reached thermal balance in the test chamber. The equipment shall be switched off during the temperature stabilizing period.

In the case of equipment containing temperature stabilization circuits designed to operate continuously, the temperature stabilization circuits shall be switched on for 15 minutes after thermal balance has been obtained, and the equipment shall then meet the specified requirements.

If the thermal balance is not checked by measurements, a temperature stabilizing period of at least one hour, or such period as may be decided by the accredited test laboratory, shall be allowed. The sequence of measurements shall be chosen, and the humidity content in the test chamber shall be controlled so that excessive condensation does not occur.

If the equipment is incapable of transmitting an unmodulated carrier, an actual digital data sequence or a pseudorandom sequence representative of an actual digital data transmission shall be used to modulate the carrier (see clauses 5.1.10.5 and 5.1.10.5.1).

5.1.10.4.1.1.1 Procedure for equipment designed for continuous operation

If the applicant states that the equipment is designed for continuous operation, the test procedure shall be as follows:

- before conducting tests at the upper extreme temperature the equipment shall be placed in the test chamber and left until thermal balance is attained. The equipment shall then be switched on in the transmit condition for a period of time specified by the manufacturer to be the maximum time the equipment will transmit in normal operation after which the equipment shall meet the specified requirements;
- for tests at the lower extreme temperature, the equipment shall be left in the test chamber until thermal balance is attained, then switched on for a period of one minute after which the equipment shall meet the specified requirements.

5.1.10.4.1.1.2 Procedure for equipment designed for intermittent operation

If the applicant states that the equipment is designed for intermittent operation, the test procedure shall be as follows:

- before tests at the upper extreme temperature the equipment shall be placed in the test chamber and left until thermal balance is attained in the oven. The equipment shall then either:
 - transmit on and off according to the applicants declared duty cycle for a period of five minutes; or
 - if the applicant's declared on period exceeds one minute, then transmit in the on condition for a period not exceeding one minute, followed by a period in the off or standby mode for four minutes; after which the equipment shall meet the specified requirements;

- for tests at the lower extreme temperature, the equipment shall be left in the test chamber until thermal balance is attained, then switched to the standby or receive condition for one minute after which the equipment shall meet the specified requirements.

5.1.10.4.1.2 Extreme temperature ranges

For tests at extreme temperatures, measurements shall be made in accordance with the procedures specified in clause 5.1.10.4.1.1, at the upper and lower temperatures of one of the following ranges.

Table 6: Extreme temperature ranges

Category I (General)	-20 °C to +55 °C
Category II (Portable equipment for outdoor use)	-10 °C to +55 °C
Category III (Equipment for normal indoor use) (see note 1)	0 °C to +55 °C
Category IV (Active Medical Implant transmitters) (see note 2)	+25 °C to +45 °C
NOTE 1: The term "equipment for normal indoor use" is taken to mean that the room temperature is controlled and the minimum indoor temperature is equal to or greater than 5 °C.	
NOTE 2: The term "Active Medical Implant transmitters" refers only to equipment that is intended to be placed inside a human body during normal operation. The range of +25 °C to +45 °C is the core body temperature variation over which a human body can survive.	

The manufacturer may define a different temperature range than specified above for any category provided the EUT meets the conditions set forth below. For specific applications, the manufacturer can specify wider temperature ranges than given as a minimum above. In this case the test report shall show compliance with the limits in the present document over the extended ranges specified by the manufacturer. This shall be reflected in the manufacturers' product literature. Narrower temperature ranges than given above may be implemented provided the reduced range is reflected in the manufacturers' product literature and the test report shows that the device implements techniques which do not allow it to exceed the limits specified in the present document over the minimum ranges given above.

The equipment shall comply with all the technical requirements of the present document at all times when operating within the boundary limits of the required operational temperature profile.

For special applications, the manufacturer can specify wider temperature ranges than given as a minimum above. This shall be reflected in manufacturers' product literature.

The test report shall state which range is used.

5.1.10.4.2 Extreme test source voltages

5.1.10.4.2.1 Mains voltage

The extreme test voltages for equipment to be connected to an ac mains source shall be the nominal mains voltage $\pm 10\%$. For equipment operating over a range of mains voltages clause 5.1.10.4.2.4 applies.

5.1.10.4.2.2 Regulated lead-acid battery power sources

When the radio equipment is intended for operation from the usual type of regulated lead-acid battery power sources the extreme test voltages shall be 1,3 and 0,9 multiplied by the nominal voltage of the battery (6 V, 12 V, etc.).

For float charge applications using "gel-cell" type batteries the extreme voltage shall be 1,15 and 0,85 multiplied by the nominal voltage of the declared battery voltage.

5.1.10.4.2.3 Power sources using other types of batteries

The lower extreme test voltages for equipment with power sources using batteries shall be as follows:

- for equipment with a battery indicator, the end point voltage as indicated;

- for equipment without a battery indicator the following end point voltages shall be used:
 - a) for the Leclanché or the lithium type of battery:
 - 0,85 multiplied by the nominal voltage of the battery;
 - b) for the nickel-cadmium type of battery:
 - 0,9 multiplied the nominal voltage of the battery.

The nominal voltage is considered to be the upper extreme test voltage in this case.

5.1.10.4.2.4 Other power sources

For equipment using other power sources, or capable of being operated from a variety of power sources, the extreme test voltages shall be according to manufactures specification.

5.1.10.5 Normal test signals and test modulation

5.1.10.5.0 General remarks

The test modulating signal is a signal which modulates a carrier, is dependent upon the type of equipment under test and also the measurement to be performed. Modulation test signals only apply to products with an external modulation connector. For equipment without an external modulation connector, normal operating modulation shall be used.

5.1.10.5.1 Normal modulation test signals for data

Normal test signals for data are specified as follows:

- D-M2: a test signal representing a pseudo-random bit sequence of at least 511 bits in accordance with Recommendation ITU-T O.153 [i.4]. This sequence shall be continuously repeated. If the sequence cannot be continuously repeated, the actual method used shall be stated in the test report.
- D-M3: a test signal shall be agreed between the accredited test laboratory and the applicant in case selective messages are used and are generated or decoded within the equipment. The agreed test signal may be formatted and may contain error detection and correction.

For angle modulation, the normal level of the test signal D-M3 shall produce a deviation of 20 % of the channel separation or any other value as declared by the applicant as the normal operating level.

In case of amplitude modulation, the modulation ratio shall be 60 %, or any value, as declared by the applicant, as the normal operating level.

For other forms of modulation, the ratio and level will be as declared by the applicant.

5.1.10.6 Antenna

5.1.10.6.0 General remarks

Equipment operating in the 9 kHz to 315 kHz band shall have an integral antenna, an external dedicated antenna or both. If provision for an external antenna connection is made, the connector shall be a unique type to prevent use of an antenna other than a dedicated antenna supplied by the manufacturer.

5.1.10.6.1 Artificial Antenna

An artificial antenna that simulates the actual antenna configuration specified by the applicant may be used only as necessary. The test laboratory and the manufacturer shall agree as to the arrangement.

5.1.10.7 Test fixture

5.1.10.7.0 General remarks

With equipment intended for use with an integral antenna, and not equipped with a 50 Ω RF output connector, a suitable test fixture may be used as agreed with the accredited test laboratory, if radiated measurements with the intended antenna cannot be made.

This fixture is a RF coupling device for coupling the integral antenna to a 50 Ω RF terminal at the working frequencies of the equipment under test. This allows certain measurements to be performed using conducted measuring methods. However, only relative measurements may be performed. The test fixture is normally only required for extreme temperature measurements and shall be calibrated only with the equipment under test.

The test fixture shall be fully described by the applicant. The accredited test laboratory, where applicable shall calibrate the test fixture by carrying out the required field measurements at normal temperatures at the prescribed test site. Then the same measurements shall be repeated on the equipment under test using the test fixture for all identified frequency components.

In addition, the test fixture may provide:

- a connection to an external power supply;
- a connection to a data interface.

The performance characteristics of the test fixture shall be agreed upon with the accredited test laboratory, where applicable and shall conform to the following basic parameters:

- the circuit associated with the RF coupling shall contain no active or non linear devices;
- the coupling loss shall not influence the measuring results;
- the coupling loss shall be independent of the position of the test fixture and be unaffected by the proximity of the surrounding objects or people;
- the coupling loss shall be reproducible when the equipment under test is removed and replaced;
- the coupling loss shall remain substantially constant when the environmental conditions are varied.

5.1.10.7.1 Alternate test fixture for equipment intended to be implanted within a human body

For measurement purposes, to determine compliance with all emission limits, active medical implants may be tested in a fixture that approximates the physical conditions of an implant transmitter placed in a human body. This fixture, a human torso simulator, with the implant mounted inside, shall be filled with a tissue substitute material and placed on the radiated emissions test site turntable with the implant at a height of 1,5 m above the ground plane for testing purposes. The tissue substitute material conductivity and dielectric parameters shall in accordance with clause B.1.1.3. Typically they will be equivalent to those of human muscle tissue at the fundamental frequency or alternatively these parameters may be adjusted to correspond to the measurement frequency. The tissue substitute material shall be sufficiently fluid that it will flow around the implant without creating any voids.

5.1.10.8 Test sites and general arrangements for radiated measurements

For guidance on radiation test sites, see annex B. Detailed descriptions of radiated measurement arrangements are included in this annex.

5.1.10.9 Modes of operation of the transmitter

For the purpose of the measurements according to the present document, there should preferably be a facility to operate the transmitter in an unmodulated state. The method of achieving an unmodulated carrier frequency or special types of modulation patterns may also be decided by agreement between the applicant and the accredited test laboratory. It shall be described in the test report. It may involve suitable temporary internal modifications of the equipment under test. If it is not possible to provide an unmodulated carrier then this shall be stated in the test report.

For the purpose of type testing, the normal test signal, see clauses 5.1.10.5 and 5.1.10.5.1, shall be applied to the input of the transmitter under test with the normal input device disconnected when possible.

5.1.10.10 Measuring receiver

The term "measuring receiver" refers to a selective voltmeter or a spectrum analyser. The bandwidth and detector type of the measuring receiver are given in table 7. Measurements above 30 MHz are not required.

Table 7

Frequency (f)	Detector type	Bandwidth
$9 \text{ kHz} \leq f < 150 \text{ kHz}$	Quasi Peak	200 Hz to 300 Hz
$150 \text{ kHz} \leq f < 30 \text{ MHz}$	Quasi Peak	9 kHz to 10 kHz

Exceptionally, a different bandwidth may be used for narrow band signals if agreed with the accredited test laboratory. This shall be stated in the test report.

5.2 Interpretation of the measurement results

The interpretation of the results recorded in the test report for the measurements described in the present document shall be as follows:

- the measured value related to the corresponding limit shall be used to decide whether an equipment meets the requirements of the present document;
- the value of the measurement uncertainty for the measurement of each parameter shall be separately included in the test report;
- the value of the measurement uncertainty shall be, for each measurement, equal to or lower than the figures given in table 8 below.

Table 8

RF frequency	$\pm 1 \times 10^{-7}$
RF power, conducted	$\pm 1 \text{ dB}$
RF power, radiated	$\pm 6 \text{ dB}$
Temperature	$\pm 1 \text{ }^\circ\text{C}$
Humidity	$\pm 5 \%$

For the test methods, according to the present document the uncertainty figures shall be calculated according to the methods described in the ETSI TR 100 028 [i.3] and shall correspond to an expansion factor (coverage factor) $k = 1,96$ or $k = 2$ (which provide confidence levels of respectively 95 % and 95,45 % for the case where the distributions characterizing the actual measurement uncertainties are normal (Gaussian)).

The measurement uncertainties given above are based on such expansion factors.

The particular expansion factor used for the evaluation of the measurement uncertainty shall be stated.

5.3 Method of Measurements

5.3.1 Radiated field strength

5.3.1.0 General remarks

To meet the requirements of the present document, the transmitter shall be measured at the radiated H-field, conducted current or power level as declared by the applicant.

Where the transmitter is designed with an adjustable carrier H-field or RF current, all parameters shall be measured using the highest output level as declared by the applicant. The equipment shall then be adjusted to the lowest setting, as declared by the applicant, and the spurious emissions measurement shall be repeated (see clause 5.3.3).

If the equipment is supplied with an integral antenna and a permanent antenna connector to be used with a dedicated antenna, the following full tests shall be carried out using the integral antenna and the dedicated antenna connected to the external connector:

- radiated H-field (see clause 5.3.1.1);
- spurious emissions (see clause 5.3.3).

5.3.1.1 Radiated Field Strength (H-field)

The measurements shall be made on an open field test site as specified in annex B. Any measured values shall be at least 6 dB above the ambient noise level.

The H-field produced by the equipment shall be measured at standard distance of 10 m. Where this is not practical, e.g. due to low power of the equipment including the antenna or with use of special field cancelling antenna, then other distances may be used. When another distance is used, the distance used and the field strength value measured shall be stated in the test report. In this case, the measured value at the actual test distance shall be extrapolated to 10 m and stated in the test report.

The H-field is measured with a shielded loop antenna connected to a measurement receiver. The measuring bandwidth and detector type of the measurement receiver shall be in accordance with clause 5.1.10.10.

The equipment under test shall operate where possible, without modulation. Where this is not possible, it shall be stated in the test report.

For transmitters using a continuous wideband swept carrier or stepped frequency function, the measurement shall be made with the sweep or stepping off. When it is not possible to turn the sweep off the measurements shall be made with the sweep on using a peak detector and this shall be stated in the test report.

For measuring equipment calibrated in dB μ V, the reading should be reduced by 51,5 dB to be converted to dB μ A/m.

5.3.2 Permitted frequency range of the modulation bandwidth

The transmitter shall be connected to all manufacturer supplied antenna(s). The spectrum analyser shall be connected to a shielded loop antenna placed at any convenient distance from the transmitter antenna.

The transmitter shall be operated at the nominal carrier power or field strength measured under normal test conditions in clause 4.2.1. The attenuator shall be adjusted to an appropriate level displayed at the spectrum analyser screen.

The transmitter shall be modulated with standard test modulation (see clauses 5.1.10.5 and 5.1.10.5.1). If the equipment cannot be modulated externally, the internal modulating signal shall be used.

For transmitters using a continuous wideband swept carrier the measurement shall be made with the sweep on.

The output of the transmitter, with or without test fixture, shall be measured by using a spectrum analyser with a resolution bandwidth appropriate to accept all major side bands. Normally this would be a resolution bandwidth setting of approximately 1 % of the 20 dB bandwidth. The power level calibration of the spectrum analyser shall then be related to the power level or field strength measured in clause 4.2.1. The calculation will be used to calculate the absolute level of the sideband power.

The test laboratory shall ensure that the spectrum analyser's span is sufficiently wide enough to ensure that the carrier and all its major side bands are captured.

The difference between the frequencies of the upper and lower points, where the displayed power envelope of the modulation including frequency drift is equal to the appropriate level defined in clause 4.2.2.1 is recorded as the modulation bandwidth.

The measurements shall be made during normal and extreme test conditions (clause 5.1.10.1).

5.3.3 Spurious emissions

This applies to all Product Classes.

The field strength shall be measured for frequencies below 30 MHz. The equipment under test shall be measured at a distance of 10 m on an outdoor test site. The test antenna shall be a calibrated shielded magnetic field antenna. The equipment under test and test antenna shall be arranged as stated in clause B.1.1.

The equipment under test shall be switched on with normal modulation. The characteristics of the modulation signal used shall be stated in the test report. The measuring receiver shall be tuned over the frequency range 9 kHz to 30 MHz, except for the frequency band in which the transmitter is intended to operate.

At each frequency at which a relevant spurious signal is detected the equipment under test and the test antenna shall be rotated until maximum field strength is indicated on the measuring receiver. This level shall be noted.

If the transmitter can be operated in the standby mode, then the measurements shall be repeated in the standby mode.

For measuring equipment calibrated in dB μ V, the reading should be reduced by 51,5 dB to be converted to dB μ A/m.

5.3.4 Receiver requirement

5.3.4.1 Blocking

This measurement shall be conducted under normal conditions.

Two signal generators A and B shall be connected to the receiver via a combining network to the receiver either:

- a) via a test fixture or a test antenna that couples to the receiver integral or dedicated antenna; or
- b) via a test fixture directly to the receiver permanent or temporary antenna connector.

The method of coupling to the receiver shall be stated in the test report.

Signal generator A shall be at the nominal frequency of the receiver, with normal modulation of the wanted signal. Signal generator B shall be unmodulated and shall be adjusted to a test frequency above that of the upper band edge as defined below.

Initially signal generator B shall be switched off and by using signal generator A the minimum level giving sufficient response shall be established. The output level of generator A shall then be increased by 3 dB.

Signal generator B is then switched on and adjusted until the wanted criteria is met. For purposes of this test, the criteria are considered to be met as long as the receiver always protects the health and safety of the patient. For example, techniques that accomplish this may detect corrupted data and mark it as invalid data or the data link may cease functioning during this phase of the testing. The nature of the technique used to protect the patient and the level at which it functions to provide this protection shall be stated in the test report.

The frequency for generator B is defined by the following procedure:

- receiving upper band edge: highest operating receiver frequency + receiver bandwidth;
- receiving lower band edge: lowest operating receiver frequency - receiver bandwidth.

The receiver centre frequency and bandwidth may be measured or may be declared by the manufacturer.

For systems with swept operating frequencies:

- receiving upper band edge: high end of sweep range + receiver bandwidth;
- receiving lower band edge: low end of sweep range - receiver bandwidth.

The receiver bandwidth and sweeping range may be measured or may be declared by the manufacturer.

For blocking measurements above the receive frequency:

- The frequency for generator B is calculated as the upper band edge plus an offset multiplier of the receiver bandwidth.

For blocking measurements below the receive frequency:

- The frequency for generator B is calculated as the lower band edge minus an offset multiplier of the receiver bandwidth.

The blocking shall be recorded as the ratio in dB of lowest level of the unwanted signal (generator B) to the level of the wanted signal (generator A).

5.3.4.2 Receiver spurious radiation

The method of measurement defined in clause 5.3.3 shall be used.

Convert reading by 51,5 dB for measuring equipment calibrated in dB μ V or dB μ V/m.

Annex A (normative): Relationship between the present document and the essential requirements of Directive 2014/53/EU

The present document has been prepared under the Commission's standardisation request C(2015) 5376 final [i.6] to provide one voluntary means of conforming to the essential requirements of Directive 2014/53/EU on the harmonisation of the laws of the Member States relating to the making available on the market of radio equipment and repealing Directive 1999/5/EC [i.2].

Once the present document is cited in the Official Journal of the European Union under that Directive, compliance with the normative clauses of the present document given in table A.1 confers, within the limits of the scope of the present document, a presumption of conformity with the corresponding essential requirements of that Directive and associated EFTA regulations.

Table A.1: Relationship between the present document and the essential requirements of Directive 2014/53/EU

Harmonised Standard ETSI EN 302 195				
The following requirements are relevant to the presumption of conformity under the article 3.2 of Directive 2014/53/EU [i.2]				
Requirement			Requirement Conditionality	
No	Description	Reference: Clause No	U/C	Condition
1	Radiated Field Strength	4.2.1	U	
2	Permitted range of modulation bandwidth	4.2.2	U	
3	Spurious emissions	4.2.3	U	
4	Duty cycle	4.2.4	U	
5	Receiver blocking	4.3.2	U	
6	Receiver spurious radiations	4.3.3	U	

Key to columns:

Requirement:

No A unique identifier for one row of the table which may be used to identify a requirement.

Description A textual reference to the requirement.

Clause Number Identification of clause(s) defining the requirement in the present document unless another document is referenced explicitly.

Requirement Conditionality:

U/C Indicates whether the requirement shall be unconditionally applicable (U) or is conditional upon the manufacturers claimed functionality of the equipment (C).

Condition Explains the conditions when the requirement shall or shall not be applicable for a requirement which is classified "conditional".

Presumption of conformity stays valid only as long as a reference to the present document is maintained in the list published in the Official Journal of the European Union. Users of the present document should consult frequently the latest list published in the Official Journal of the European Union.

Other Union legislation may be applicable to the product(s) falling within the scope of the present document.

Annex B (normative): Radiated measurements

B.1 Test sites and general arrangements for measurements involving the use of radiated fields

B.1.1 Outdoor test site

B.1.1.0 General remarks

The outdoor test site shall be on a reasonably level surface or ground. For measurements at frequencies below 30 MHz no artificial ground plane shall be used and the measurement antenna shall be of a shielded loop type and placed on a table of 1-m height placed 10 m from the EUT. Closer distances are permitted if measurements of low level emissions are performed. For measurements at frequencies 30 MHz and above, a conducting ground plane of at least 5 m diameter shall be provided at one point on the site. In the middle of this ground plane, a non-conducting support, capable of rotation through 360° in the horizontal plane, shall be used to support the test sample in its standard position, at 1 m above the ground plane, with the exception of equipment with floor standing antenna. For this equipment, the antenna shall be raised, on a non-conducting support, 100 mm above the turntable, the point(s) of contact being consistent with normal use. The test site shall be large enough to allow the erection of a measuring or transmitting antenna at a distance of 10 m or optionally 30 m. The distance actually used shall be recorded with the results of the tests carried out on the site.

Sufficient precautions shall be taken to ensure that reflections from extraneous objects adjacent to the site do not degrade the measurements results.

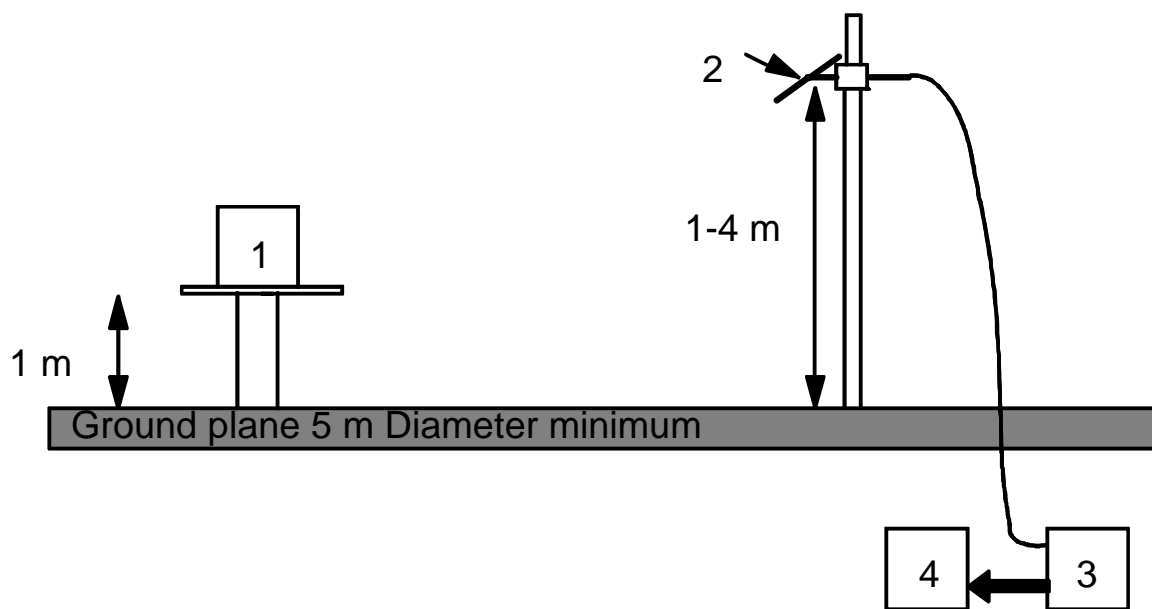

Figure B.1

B.1.1.1 Standard position

The standard position in all test sites, except for equipment which is intended to be worn on a person, shall be as follows:

- for equipment with an integral antenna, it shall be placed in the position closest to normal use as declared by the manufacturer;

- for equipment with a rigid external antenna, the antenna shall be vertical;
- for equipment with non-rigid external antenna, the antenna shall be extended vertically upwards by a non-conducting support.

For equipment intended to be worn close to the body or hand held, the non-conducting support may, at the request of the applicant be replaced with a simulated man, if appropriate. The use of the simulated man shall be stated in the test report.

The simulated man shall consist of an acrylic tube, filled with salt water (1,5 grams NaCl per litre of distilled water). The tube shall have a length of $1,7\text{ m} \pm 0,1\text{ m}$ and an internal diameter of $300\text{ mm} \pm 5\text{ mm}$ with side wall thickness of $1,5\text{ mm} \pm 0,5\text{ mm}$.

To reduce the weight of the simulated man it may be possible to use an alternative tube, which has a hollow centre of 200 mm maximum diameter.

The sample shall be fixed to the surface of the simulated man, at the appropriate height for the equipment.

B.1.1.2 Equipment in close proximity to the human body but external to it

The following provisions apply to equipment designed to be external to but in very close proximity to a human body.

For programmer/control equipment intended to be worn close to the body or hand held, the non-conducting support may, at the request of the applicant be replaced with a simulated man, if appropriate. The use of the simulated man shall be stated in the test report.

The simulated man for equipment external to the body shall consist of an acrylic tube, filled with salt water (1,5 g NaCl per litre of distilled water). The tube shall have a length of $1,7\text{ m} \pm 0,1\text{ m}$ and an internal diameter of $300\text{ mm} \pm 5\text{ mm}$ with side wall thickness of $1,5\text{ mm} \pm 0,5\text{ mm}$.

To reduce the weight of the simulated man it may be possible to use an alternative tube that has a hollow centre of 200 mm maximum diameter.

The sample shall be fixed to the surface of the simulated man, at the appropriate height for the equipment.

The following provisions apply to equipment designed to be implanted in a human body.

B.1.1.3 Active medical implant equipment

Equipment intended to be implanted in a human body for purposes of the present document should be tested in a simulated man constructed as follows in order to simulate operation of the implant under actual operating conditions as shown in figure B.2.

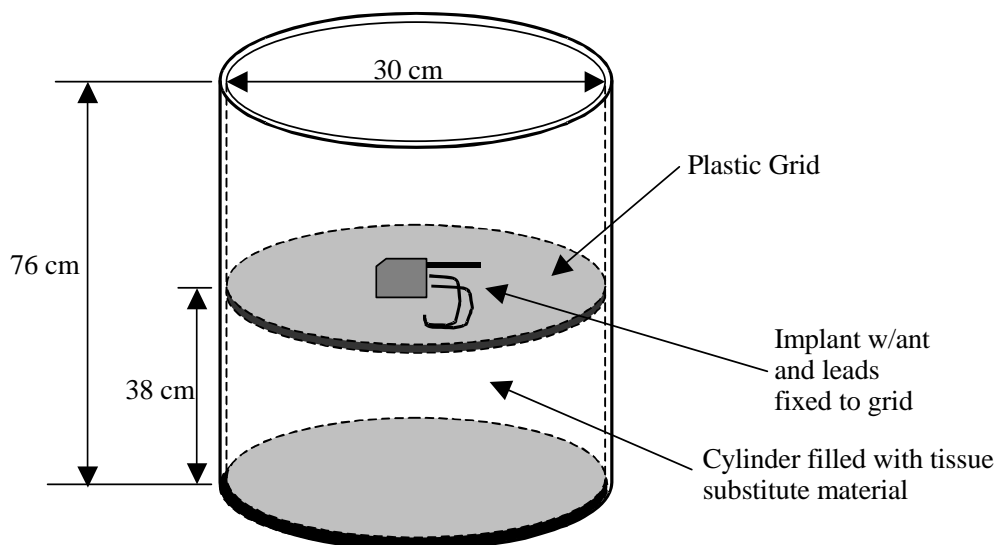

Figure B.2

A torso simulator for testing medical implant transmitters consists of a cylindrical acrylic container with a size of $30\text{ cm} \pm 0,5\text{ cm}$ by $76\text{ cm} \pm 0,5\text{ cm}$ with a sidewall thickness of $0,635\text{ cm} \pm 0,05\text{ cm}$. It shall be completely filled with a material that is sufficiently fluid that it will flow around the implant without any voids.

The dielectric and conductivity properties of this material should match the dielectric and conductivity properties of human muscle tissue at the centre frequency of operation or, if desired, at the measurement frequency. The saline solution specified below may be used for this purpose; however, it typically will not match these properties.

All radiated emissions measurements will be made using the above torso simulator with the tissue substitute material at a nominal temperature between $22\text{ }^{\circ}\text{C}$ and $38\text{ }^{\circ}\text{C}$.

NOTE 1: This temperature will facilitate testing because it is representative of ambient conditions at many test sites.

A mounting fixture for the implant inside the container shall be provided that permits the radiating element or elements of the implant to be positioned vertically and horizontally. The fixture should also support any additional implant leads associated with the therapeutic function of the implant in a fixed repeatable manner such that they do not influence the measurement.

NOTE 2: In this frequency range, implant antennas are normally enclosed with the case of the implant.

For testing purposes the side of the implant case that is in closest proximity to the internal antenna shall be mounted in a vertical plane no further than $6\text{ cm} \pm 0,5\text{ cm}$ from the sidewall of the container and centred vertically within the container. When switching from vertical to horizontal positioning, the implant case shall be mounted as above except the side of the case shall be mounted in a horizontal plane. In this case it may be necessary to reposition the implant to maintain a separation as above no greater than $6\text{ cm} \pm 0,5\text{ cm}$ from the sidewall of the test fixture along its length. Implant leads shall be coiled and placed away from the implant antenna while maintaining a nominal 6 cm from the sidewall.

The above fixture shall be placed on a turntable such that the implant transmitter is located at a nominal 1,5 m above ground and at a 3 m distance from the measurement antenna.

Radiated emissions measurements shall then be performed to ensure compliance with the applicable technical specifications. In situations where the implant case that is in closest proximity to the internal antenna is unknown, the implant position will be investigated to determine the position producing maximum emissions. Data shall be recorded for this position to determine conformance with the applicable limit.

Implants that are designed to communicate with an external device may require the presence of the external device in order to transmit. Manufacturers should note that it is desirable if possible to activate normal implant transmitter function via a technique that does not require an external accessory device such as a programmer to be used.

Tissue parameters for various frequencies may be obtained from the following website: <http://niremf.ifac.cnr.it>, maintained by the Italian National Research Council, Institute for Applied Physics. Other sources can be used provided they are based on the 4-Cole-Cole equations developed by Gabriel [i.5]. A saline solution recognized by the medical industry as a tissue medium may be used if desired by the manufacturer. As guidance, a saline solution producing a 375 Ω -cm conductivity using a standard test cell meets this requirement.

B.1.2 Test antenna

B.1.2.1 Below 30 MHz

A calibrated loop antenna shall be used to detect the field strength from the test sample. The antenna shall be supported in the vertical plane and be rotated about a vertical axis. The lowest point of the loop shall be 1 m above ground level.

B.1.3 Optional additional indoor site

When the frequency of the signals being measured is greater than 80 MHz, use may be made of an indoor test site. If this alternative site is used, this shall be recorded in the test report.

The measurement site may be a laboratory room with a minimum area of 6 m by 7 m and at least 2,7 m in height.

Apart from the measuring apparatus and the operator, the room shall be as free as possible from reflecting objects other than the walls, floor and ceiling.

The potential reflections from the wall behind the equipment under test are reduced by placing a barrier of absorbent material in front of it. The corner reflector around the test antenna is used to reduce the effect of reflections from the opposite wall and from the floor and ceiling, in the case of horizontally polarized measurements. Similarly, the corner reflector reduces the effects of reflections from the sidewalls for vertically polarized measurements. For the lower part of the frequency range (below approximately 175 MHz), no corner reflector or absorbent barrier is needed. For practical reasons, the $\lambda/2$ antenna in figure B.2 may be replaced by an antenna of constant length, provided that this length is between $\lambda/4$ and λ at the frequency of measurement, and the sensitivity of the measuring system is sufficient. In the same way, the distance of $\lambda/2$ to the apex may be varied.

The test antenna, measuring receiver, substitution antenna and calibrated signal generator are used in a way similar to that of the general method. To ensure that errors are not caused by the propagation path approaching the point at which phase cancellation between the direct and the remaining reflected signals occurs, the substitution antenna shall be moved through a distance of $\pm 0,1$ m in the direction of the test antenna as well as in the two directions perpendicular to this first direction.

If these changes of distance cause a signal change of greater than 2 dB, the test sample should be re-sited until a change of less than 2 dB is obtained.

B.2 Guidance on the use of radiation test sites

B.2.0 General remarks

For measurements involving the use of radiated fields, use may be made of a test site in conformity with the requirements of clause B.1. When using such a test site, the following conditions should be observed to ensure consistency of measuring results.

B.2.1 Measuring distance

Evidence indicates that the measuring distance is not critical and does not significantly affect the measuring results. For ULP-AMI inductive systems covered by the present document, the measurement distance should generally be 10 m or less. Precautions described in this annex are to be observed. Measurements at low frequencies and distances less than $\lambda/2$ are considered in the present document and shall be followed. Measuring distances of 3 m, 5 m, 10 m and 30 m are in common use in European test laboratories. Measurements at distances different to 10 m need to have a correction factor added to give a resultant at 10 m so that comparison with the limit is possible. The correction factor used shall be stated and justified in the test report.

B.2.2 Auxiliary cables

The position of auxiliary cables (power supply and microphone cables, etc.) which are not adequately de-coupled, may cause variations in the measurement results. In order to get reproducible results, cables and wires of auxiliaries should be arranged vertically downwards (through a hole in the non conducting support), or as specified in the technical documentation supplied with the equipment.

Care shall be taken to ensure that test cables do not adversely affect the measuring result.

Annex C (normative): H-field measurements at other distances than 10 m

Measurements at longer distances than 10 m may be relevant for equipment using combination loop antennas having an increased reduction of the radiated H-field versus distance. An example of this performance is a "configure eight antenna" having two identical but physical spaced antenna loops driven with opposite phased currents.

The present document allows field measurements to be made at other distances than 10 m. In this case, the appropriate H-field limit, H_x , for applicant requested measurement distance, d_x , shall be calculated. The calculation of the new limit, H_x , shall be made by the applicant. Both the calculation of new limit and the requested measurement distance shall be stated in the Application and Test Report.

The following procedure shall be used:

- a) For $\frac{\lambda}{2\pi} \geq 3d(m)$;

where d is either 10 m or the new measurements distance, d_x , whichever is the longest.

The new limit H_x in dB μ A/m at distance d_x is determined from the 10 m limit H_{10} in dB μ A/m by:

$$H_x = H_{10} + 60 \times \log \frac{10}{d_x} (\text{dB}\mu\text{A}/\text{m}) \quad (\text{C.1})$$

- b) For $\frac{\lambda}{2\pi} \leq 0,3d(m)$;

where d is either 10 m or the new measurements distance d_x whichever is the shortest.

The new limit H_x in dB μ A/m at distance d_x is determined from the 10 m limit H_{10} in dB μ A/m by:

$$H_x = H_{10} + 20 \times \log \frac{10}{d_x} (\text{dB}\mu\text{A}/\text{m}) \quad (\text{C.2})$$

- c) If $\frac{\lambda}{2\pi}$ is between the two boundaries determined in a) and b) above the following steps shall be followed:

Step 1: Calculate the radian wavelength, x :

$$x = \frac{\lambda}{2\pi} = \frac{300}{2\pi f} (m); \text{ where } f \text{ is in MHz} \quad (\text{C.3})$$

Step 2: Calculate the magnetic dipole moment from the 10 m limit, H_{10} in A/m by either:

- a) for $x \times 2,354 \geq 10 m$

$$m = H_{10} \frac{2\pi x \times 10^3}{\sqrt{x^2 + 10^2}} (\text{Am}^2) \text{ or;} \quad (\text{C.4})$$

- b) for $x \times 2,354 < 10 m$

$$m = H_{10} \frac{x^2 \times 10^3 \times 4\pi}{\sqrt{x^4 - x^2 \times 10^2 + 10^4}} (\text{Am}^2) \quad (\text{C.5})$$

Step 3: Calculate the new limit H_x in A/m for the new measurements distance, d_x is calculated by either:

- a) for $d_x \leq x \times 2,354$

$$H_x = \frac{m\sqrt{x^2 + d_x^2}}{2\pi(x + d_x^3)} (A/m) \text{ or;} \quad (C.6)$$

- b) for $d_x > x \times 2,354$

$$H_x = \frac{m\sqrt{x^4 - x^2 d_x^2 + d_x^4}}{4\pi(x^2 + d_x^3)} (A/m) \quad (C.7)$$

The calculated value for H_x in A/m may be converted to dB μ A/m as appropriate.

As an example, the H-field limits at 10 m are converted to 30 m by using the above method.

Table C.1: H-field limits at 30 m

Frequency range (MHz)	H-field strength limit (H_f) dB μ A/m at 30 m
$0,009 \leq f < 0,03$	43,5 or according to note
$0,03 \leq f < 0,07$ $0,119 \leq f < 0,135$	43,5 at 0,03 MHz descending 3 dB/octave or according to note
$0,05975 \leq f < 0,06025$ $0,07 \leq f < 0,119$	13,5
$0,135 \leq f < 1,26$	8,7 at 0,135 MHz descending 3 dB/octave
$1,26 \leq f < 30$	-1
$6,765 \leq f \leq 6,795$ $13,553 \leq f \leq 13,567$ $26,957 \leq f \leq 27,283$	32,5
NOTE: For the frequency ranges 9 kHz to 70 kHz and 119 kHz to 135 kHz, the following additional restrictions apply to the higher limits: <ul style="list-style-type: none"> - for loop coil antennas with an area $\geq 0,16 \text{ m}^2$; - for loop coil antennas with an area between $0,05 \text{ m}^2$ and $0,16 \text{ m}^2$, with a correction factor. The limit is: $+10 \times \log(\text{area}/0,16 \text{ m}^2)$. 	

Annex D (informative): Bibliography

ECC Report 12 (2002): "Ultra Low Power Active Medical Implant Systems (ULP-AMI)".

Radiofrequency Radiation Dosimetry Handbook (October 1986): "USAF School of Aerospace Medicine, Aerospace Medical Division (AFSC)", Brooks Air Force Base, TX 78235-5301.

CISPR 16-1: "Specifications for radio disturbance and immunity measuring apparatus and methods; Part 1: Radio disturbance and immunity measuring apparatus".

ETSI EN 301 489-31: "ElectroMagnetic Compatibility (EMC), Standard for radio equipment and services; Part 31: Specific conditions for equipment in the 9 kHz to 315 kHz band for Ultra Low Power Active Medical Implants (ULP-AMI) and related peripheral devices (ULP-AMI-P), Harmonized Standard covering the essential requirements of Directive 2014/53/EU".

Directive 98/34/EC of the European Parliament and of the Council of 22 June 1998 laying down a procedure for the provision of information in the field of technical standards and regulations.

History

Document history		
V1.1.1	March 2004	Publication as ETSI EN 302 195 part 1 and part 2
V2.0.1	March 2016	EN Approval Procedure AP 20160614: 2016-03-16 to 2016-06-14
V2.1.1	June 2016	Publication